



**HIGHMARK
FENDER FLARES**
FOR CHEVY COLORADO



PLEASE READ BEFORE YOU START

To guarantee a quality installation, we recommend reading these instructions thoroughly before beginning any work. These instructions assume a certain amount of mechanical ability and are not written nor intended for someone not familiar with auto repair.

INCLUDED PARTS	QTY	REQUIRED TOOLS
Front Flares	2	Basic Hand Tools
Rear Flares	2	Wire Strippers
Bison OR ZR2 Wheel Liner Panel	2	Rivet Gun
Stamped A Pillar Patch Panel	2	Drill
LED Marker Light Kit	1	11/32" Drill Bit
Fastener Pack	1	13/32" Drill Bit
Templates	8	Cut-off Tool or Air Saw Rust Preventative



FRONT FLARE INSTALLATION

I. DISASSEMBLY

1. Remove Front Flares:
 - A. Remove the M4 torx bolts from inside lower wheel wells, and Push Pins from underside of flares (fig. 1).
 - B. Gently pull flare from vehicle to release all the service clips.

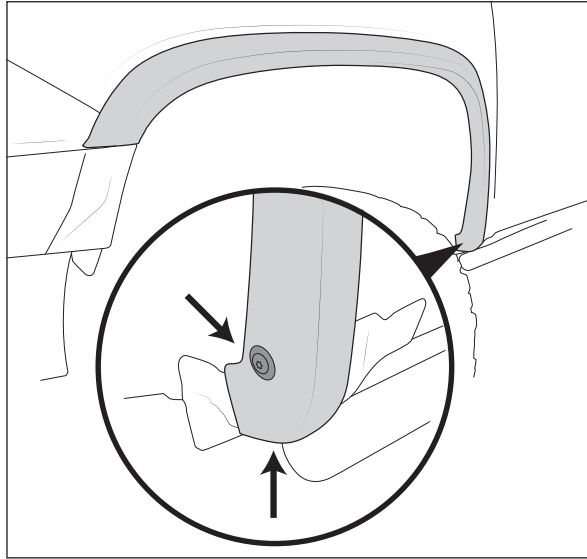

Figure 1

2. Remove Wheel liners and **SAVE**.

II. VEHICLE PREPARATION

1. Protect fenders, doors, hood, and windshield using crash wrap or welding blankets. **NOTE:** Sparks from cutting can damage paint and glass.
2. Cutout templates AEV30368 and AEV30369.
3. Adhere templates to vehicle with tape or the plastic clips from the factory flare, align the factory holes with the templates (fig. 2).

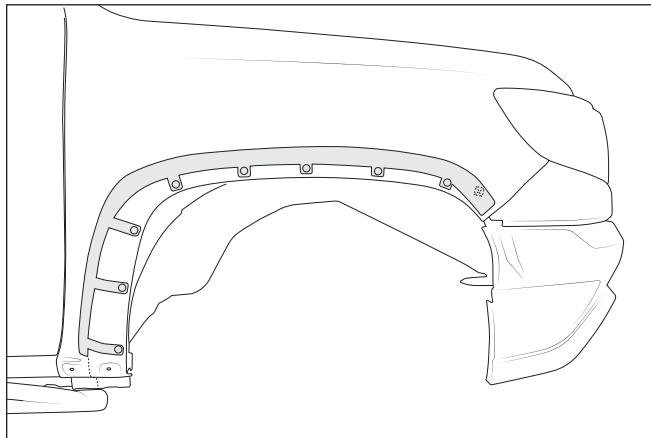

Figure 2



4. While the template is aligned with the fender, mark sheet metal along solid line as directed on template. Then remove the template and begin cutting (fig. 3).

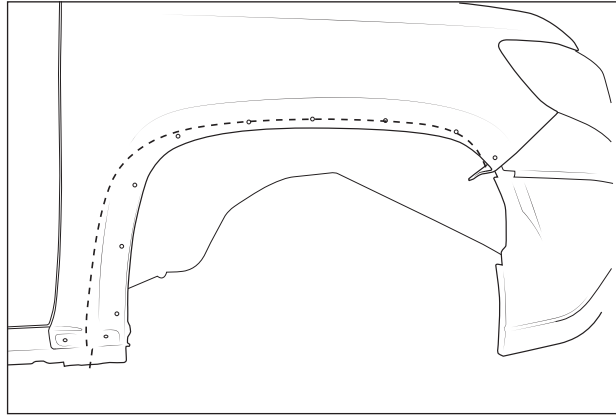

Figure 3

5. Hold flares to vehicles and center punch all holes using flare as template (fig. 4).

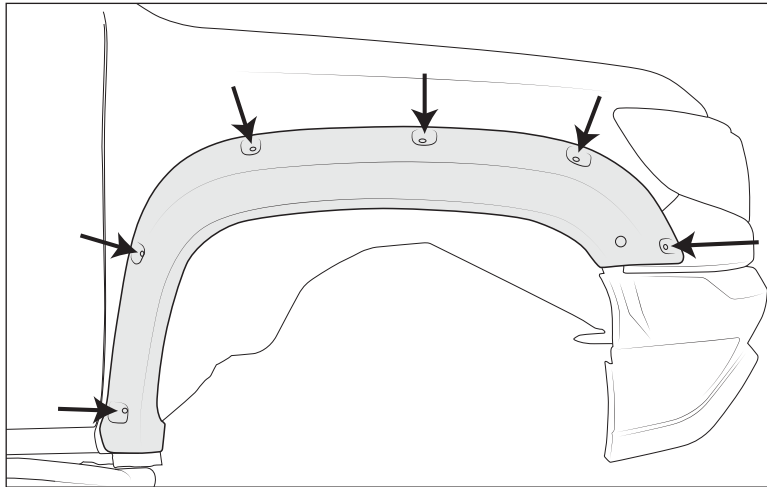

Figure 4

6. Drill all holes to 11/32" and treat bare metal with a rust preventive material.



7. Cut the pinch seams at the rear of the wheel wells and remove the shaded material (fig. 5).

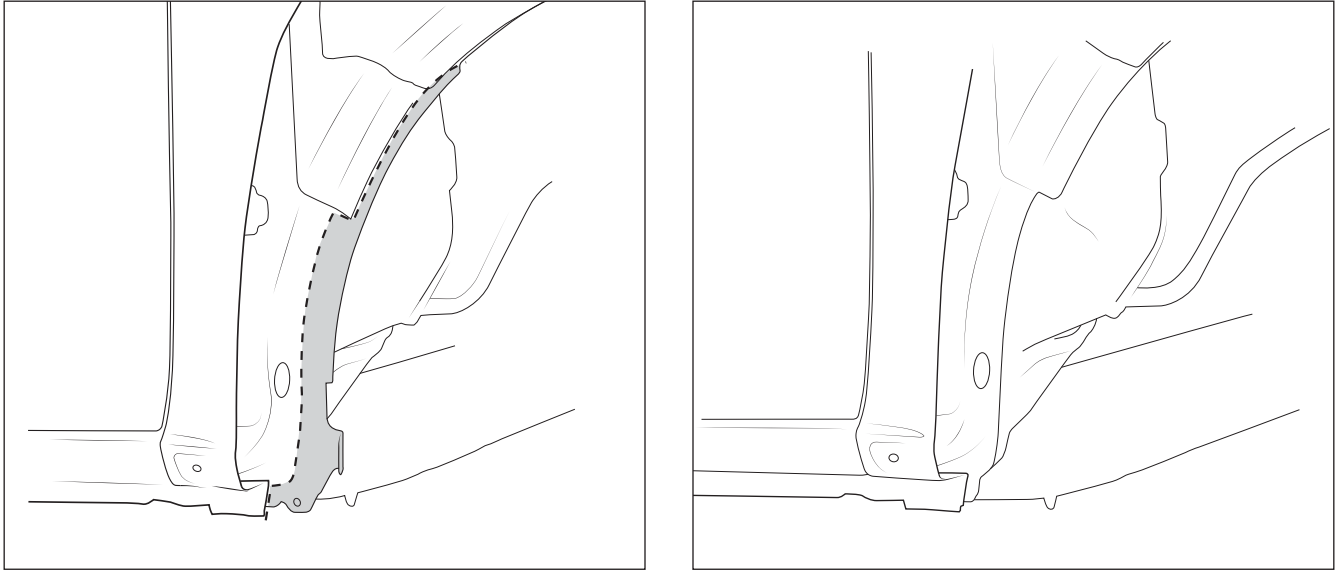

Figure 5 (Left) Before (Right) After

8. Cut pinch seams at the front of the wheel wells and remove shaded material (fig. 6).

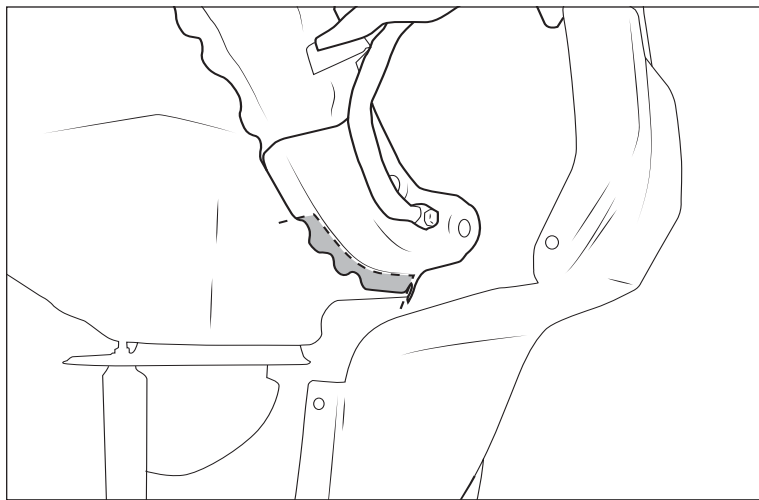

Figure 6



9. Install Closeout panels at the rear of the wheel wells (fig. 7):
 - A. Use an automotive grade panel bond for best adhesion. AEV Recommends Lord Fusor 108B.
 - B. Hold closeout panel in place and drill and rivet in 4 places. NOTE: Rivets are only there to hold panel while panel bond is setting.
 - C. Install two U-nuts per side as shown.

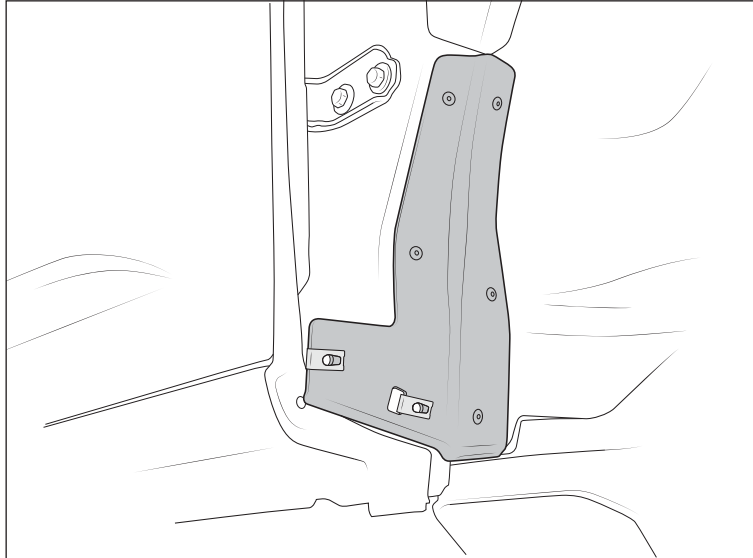

Figure 7

III. WIRING

1. Disconnect Headlight connectors.
2. Pull harness out through wheel well opening for better access.
3. Remove protective wrap from factory harness to expose wires.
4. Refer to the chart below showing which factory wires need to be spliced.
 - A. White of marker light is power: This ties into called out color on diagram.
 - B. Black of marker light is ground: This ties into black wire on factory harness.
5. Disconnect the bullet connectors from the marker light and solder to above mentioned wires.
6. Take care to properly re-insulate exposed wires.

Front Driver Side		Front Passenger Side	
AEV White	GM Violet/Gray	AEV White	GM Gray/Brown
AEV Black	GM Black	AEV Black	GM Black



IV. INSTALL FLARES

1. Install marker lights through grommets into flares (fig. 8). TIP: A little glass cleaner will help lubricate the grommets.

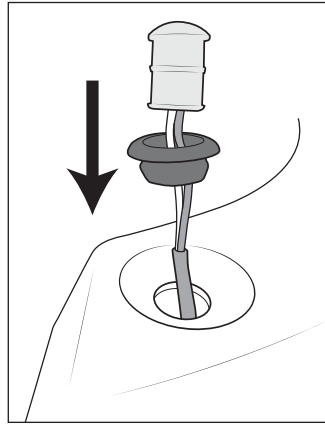

Figure 8

2. Install gimp seal.
 - A. Slide gimp seal over the body-side edge of the flare as shown (fig. 9).
 - B. Carefully pull adhesive backing away from seal to adhere to flare (fig. 9)

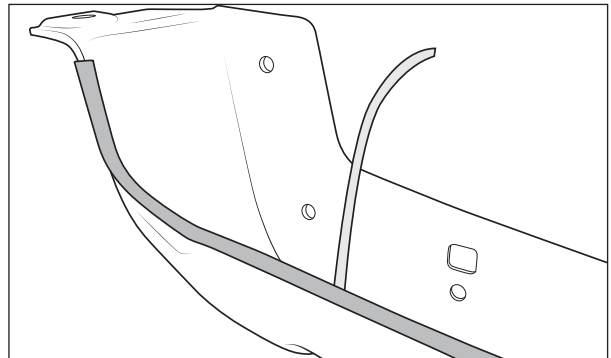
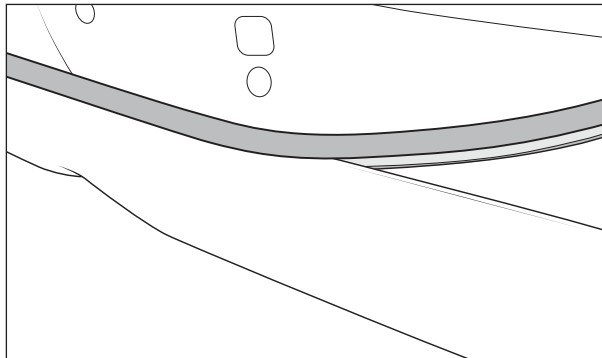

Figure 9

3. Install supplied riv-nuts into the 11/32" holes drilled in the headlamp filler panels.
4. Using the supplied M6 bolts and nuts loosely start each bolt through the flares onto body-side. NOTE: Be sure to run the marker light wiring through the hole drilled in the body.
5. Tighten each bolt evenly. Apply pressure to close any gaping.
6. Plug marker lights into wiring harness installed in section III.



7. If installing with a BISON front bumper, follow these steps (ZR2 skip to step 8):

- A. Remove closeout panels from underside of bumper. Remove four screws to remove inner panel and discard (fig. 10).

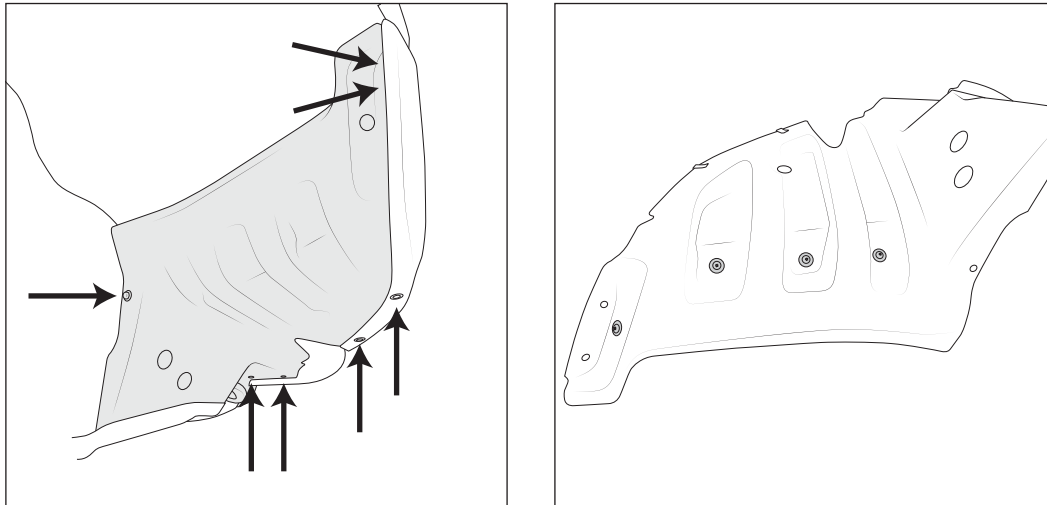

Figure 10

- B. Using template AEV30349 and AEV30346, trim the closeout panels (fig. 11).

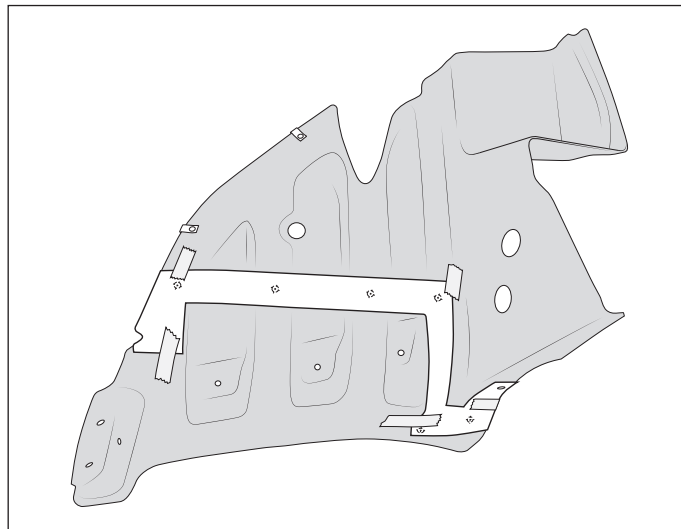

Figure 11

- C. Install four M4 u- nuts on the factory closeout panels.
- D. Re-install factory wheel liner and tuck in behind flare.
- E. Re-install factory closeout panels.
- F. Install AEV closeout panel included in kit with QTY 4 M4 bolts (fig. 12).

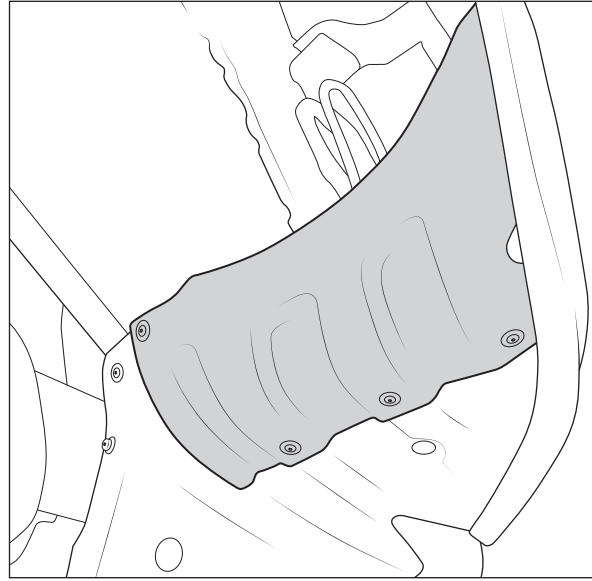

Figure 12

8. If installing with ZR2 front bumper, follow these steps:
 - A. Use Templates AEV303075 and AEV303076 to trim factory fascia (fig 13).

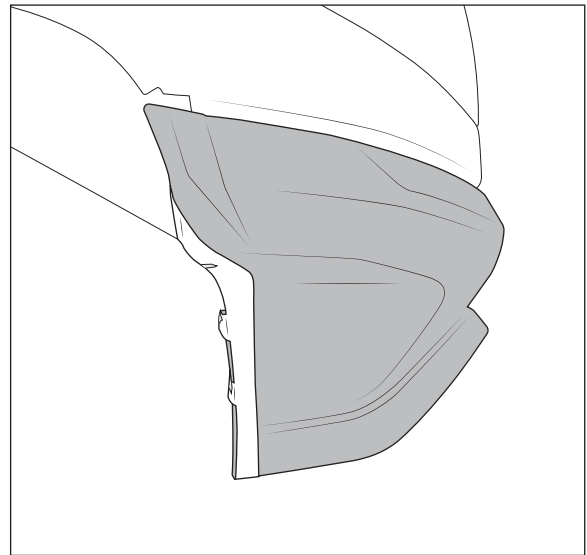
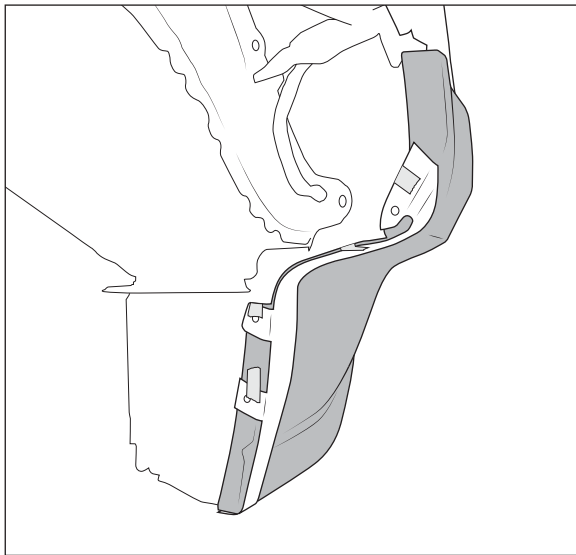

Figure 13 (Left) Backside (Right) Profile



- B. Install L brackets and u-nuts to supplied closeout panels (fig. 14).

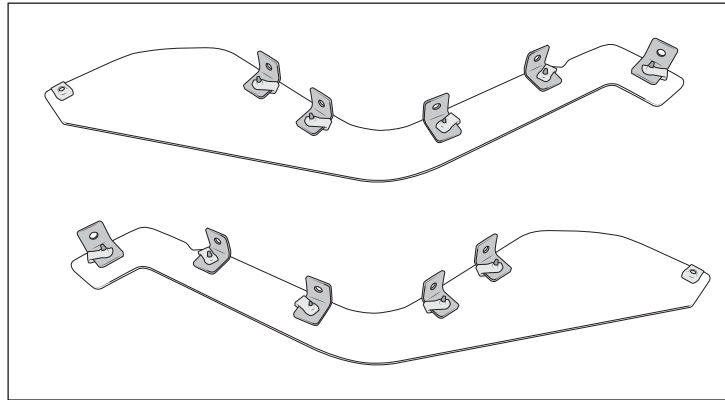

Figure 14

- C. Fasten closeout panel at top existing hole, once in place, mark and drill all remaining holes (fig. 15).

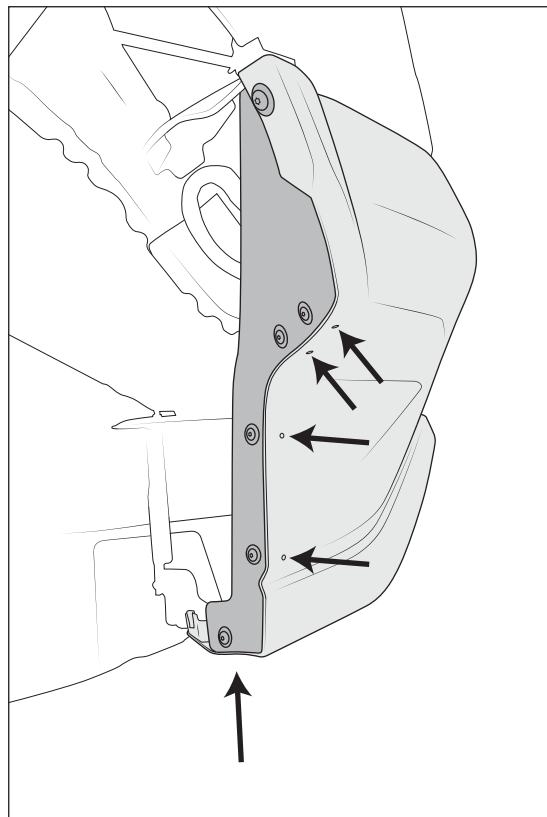

Figure 15

- D. Re-install factory wheel liner and tuck behind closeout panel and flares.
E. Install all closeout panel fasteners.



REAR FLARE INSTALLATION

I. DISASSEMBLY

1. Remove Rear Flares:
 - A. Remove M4 torx bolts from inside lower wheel wells, M4 torx bolt from underneath front side of flare, and Push Pin from underneath rear side (fig. 16).
 - B. Gently pull flare from vehicle to release all the service clips.

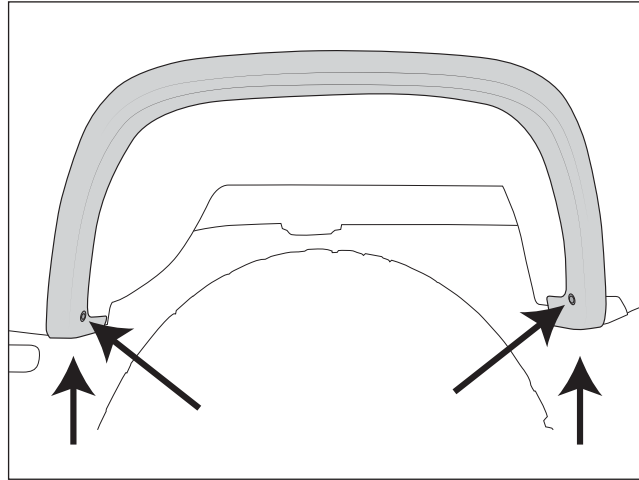

Figure 16

2. Remove Wheel liners and **SAVE**.

II. VEHICLE PREPARATION

1. Protect fenders, doors, hood, and windshield using crash wrap or welding blankets. **NOTE:** Sparks from cutting can damage paint and glass
2. Cutout templates AEV30370 and AEV30371
3. Adhere templates to vehicle with tape or the plastic clips from the factory flare, align the factory holes with the templates (fig. 17).

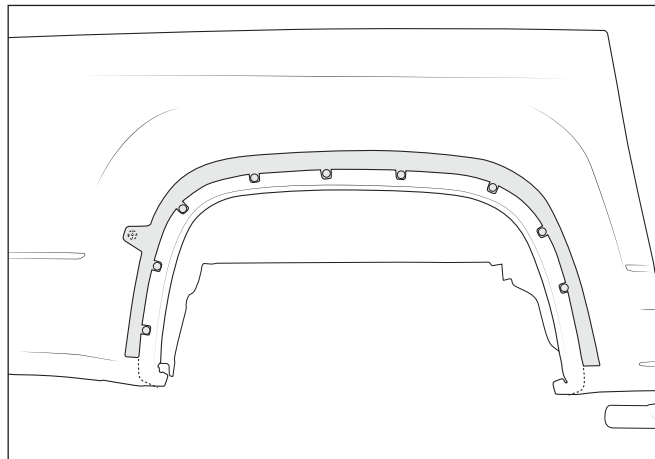

Figure 17



4. While the template is aligned with the fender, mark sheet metal along solid line as directed on template. Within the advised regions, mark the area where you will drill your holes that will be used to install spacers (fig. 18).

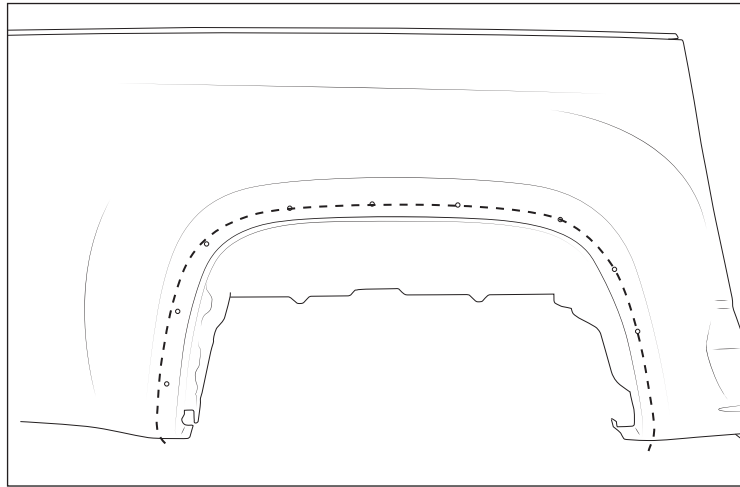

Figure 18

NOTE: It is advised to drill these holes after cutting to ensure proper placement. Then remove the template and begin cutting

5. Hold flares to vehicles and center punch all holes using flare as template (fig. 19).

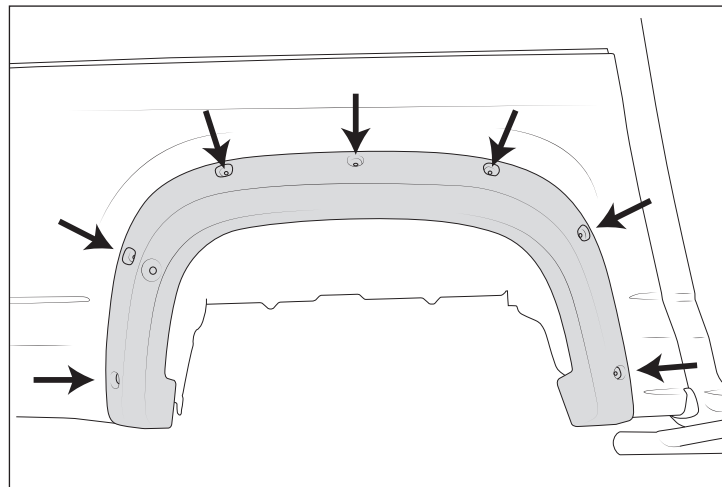

Figure 19

6. Drill all holes to $13/32$ " and treat bare metal with a rust preventive material.



7. Install Spacers (fig. 20).

A. Install QTY 7 1/4" spacers in rear

B. We recommend using an automotive grade seam sealer and bonding the panels back together. AEV Recommends Sika 252

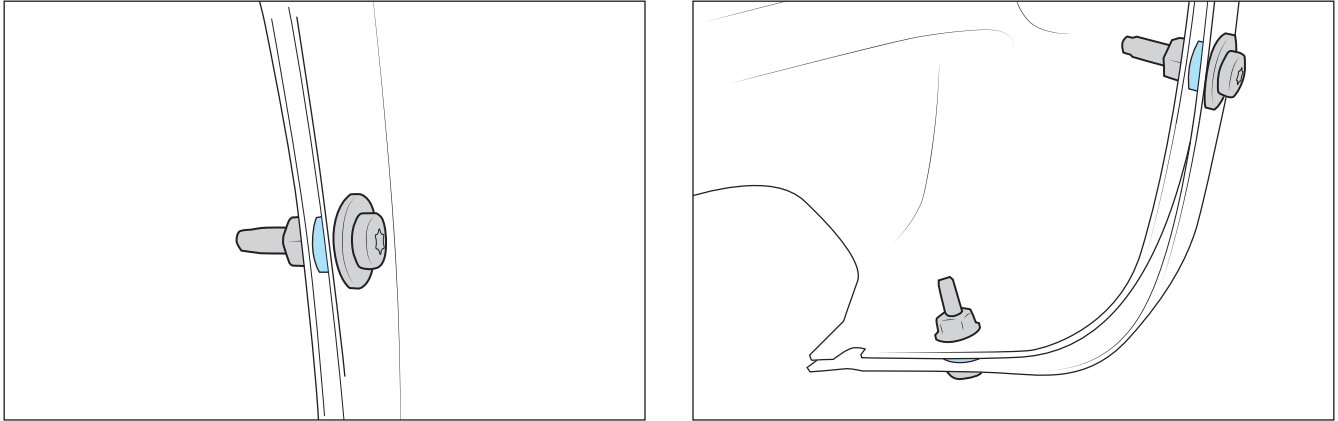

Figure 20

8. Install supplied riv-nuts into the three 11/32" holes on each bedside (fig. 21)

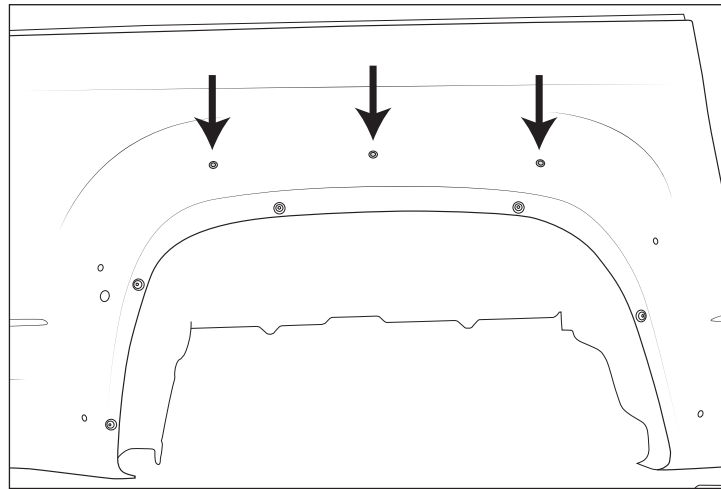

Figure 21



III. WIRING

1. Disconnect taillight connectors.
2. Pull harness down through bedside for better access.
3. Remove protective wrap from factory harness and expose wires.
4. Refer to the chart below showing which factory wires need to be spliced.
 - A. White of marker light is power: This ties into called out color on diagram.
 - B. Black of marker light is ground: This ties into black wire on factory harness.
5. Disconnect the bullet connectors from the marker light and solder to above mentioned wires.
6. Take care to properly re-insulate exposed wires.

Rear Driver Side		Rear Passenger Side	
AEV White	GM Brown/Lt. Blue	AEV White	GM Brown/Gray
AEV Black	GM Black	AEV Black	GM Black

IV. INSTALL FLARES

1. Install marker lights and grommets as shown for front flares.
2. Install gimp seal as shown for front flares.
3. Using the supplied M6 bolts and nuts loosely start each bolt through the flares onto body-side. NOTE: Be sure to run the marker light wiring through the hole drilled in the body.
4. Tighten each bolt evenly. Apply pressure to close any gaping.
5. Plug marker lights into wiring harness installed in section III.
6. Re-install factory wheel liners and tuck in behind flares.